

**BRIDGE LENGTH PERMIT POLICY**  
**NDHP Motor Carrier Division**  
**Ref: 9-2.1 (8/2023)**

**PURPOSE**

To establish guidelines when permits will be issued for legal size loads including vehicles exceeding axle weight limitations allowed on the state system, but not exceeding gross axle weight limitations allowed on the interstate system. This permit is valid for non-divisible loads that can bridge their weight. Loads exceeding allowed bridge weights will be required to purchase a single trip permit.

**POLICY STATEMENT**

As authorized by NDCC 39-12-05.3, subsection 8, the North Dakota Highway Patrol (NDHP), in cooperation with North Dakota Department of Transportation (NDDOT), may exempt certain vehicles from axle grouping gross weight limitations. The NDHP and NDDOT may designate routes to be traveled by those vehicles exempted due to bridge or other structure restrictions. The NDHP shall issue an annual bridge length permit for all vehicles to be exempted. The NDHP has the authority to inspect the vehicles and may revoke the permits at any time if the vehicles have been altered.

**PROCEDURE**

A. Vehicle Requirements

1. A single unit truck shall be allowed the same gross axle weights on the state system as allowed on the interstate system (see illustrations below).
2. Vehicles must have sufficient number of axles and bridge lengths for gross weights desired as shown on the Weight Limitations Chart.
  - a. No axle in a group of axles shall exceed 19,000 pounds.
  - b. No tire shall exceed 550 pounds per inch width of tire.
3. On a vehicle equipped with more than four axles, additional axles shall be steerable, castering, or pivoting axles.
4. Vehicles manufactured after July 31, 2005, and with more than one variable load suspension or lift axle shall have the lock or pressure regulator valve or both located outside the cab and inaccessible from the driver's compartment.
5. Tires and axle weights must be legal.
6. The maximum gross vehicle weight may not exceed 80,000 pounds.
7. Vehicles must be legally registered for the gross weight of the vehicle and load.

**B. Travel Restrictions**

1. Permit must be in possession prior to starting any movement.
2. During spring load restrictions, the weight on a group of three or more axles will be reduced to 48,000 pounds on state highways restricted by legal weights, 42,000 pounds on 8-ton highways, 36,000 pounds on 7-ton highways, and 30,000 pounds on 6-ton and 5-ton highways.
3. The bridge length permit cannot be used in conjunction with the 10-percent weight exemption permit.

**Maximum Weight**

Number of Axles	Legal Weight	8-Ton	7-Ton	6-Ton	Required Distance
4 axles	60,999	55,999	47,999	40,999	See bridge chart
5 axles	75,999	70,999	60,999	50,999	See bridge chart

**Bridge Distance**

Distance	4-Axle	5-Axle
12	50,000	
13	50,500	
14	51,500	57,000
15	52,000	57,500
16	52,500	58,000
17	53,500	58,500
18	54,000	59,500
19	54,500	60,000
20	55,500	60,500
21	56,500	61,000
22	57,500	62,000
23	58,000	62,500
24	58,500	63,000

Distance	4-Axle	5-Axle
25	59,500	63,500
26	60,000	64,500
27	60,500	65,000
28		65,500
29		66,000
30		67,000
31		67,500
32		68,000
33		68,500
34		69,500
35		70,000
36		70,500

Distance	4-Axle	5-Axle
37		71,000
38		72,000
39		72,500
40		73,000
41		73,500
42		74,500
43		75,000
44		75,500

## Application Procedure

- A. Bridge length permits may be purchased online at [www.nd.gov/ndhp](http://www.nd.gov/ndhp), click on E-permits.
  - 1. Permits purchased online are automatically issued unless submitted for review by the applicant.
  - 2. Information required to obtain a single trip permit:
    - a. Owner's name, address, and telephone number
    - b. Vehicle description: year, make, serial number, license number, registered gross vehicle weight
    - c. Axle spacings, number of tires, and tire width
    - d. Approved weight
- B. Single trip permits may also be obtained from the NDHP permit office, motor carrier inspectors, or troopers.
  - 1. Applications to the permit office may be made in person, by telephone, by e-mail, or through a permit service company.
  - 2. Applications may also be made with a trooper or motor carrier inspector, in person or by telephone.
- C. The bridge length permit will be issued to vehicles that qualify for the axle weight exemption. The annual fee is \$150, 30-day fee is \$50, and the fee for a single trip permit is \$30.
  - 1. The annual permit is valid for a twelve-month period from the date of issuance, or it expires December 31<sup>st</sup>.
  - 2. The 30-day permit is valid for 30 days.
  - 3. A single trip permit will be valid for a one-way trip not to exceed five days.
  - 4. A \$8 service/routing fee is added to each single trip permit.
- D. A legible electronic or paper copy of the permit must be in possession prior to entering North Dakota or starting movement.
  - a. The applicant/driver is responsible for complying with the travel restrictions and safety requirements listed on the permit.
- E. Any altering of equipment that has been approved for exemption will void the bridge length permit.
- F. Applications for a bridge length permit can be obtained from the North Dakota Highway Patrol, Permit Office, 600 E Boulevard Avenue Dept. 504, Bismarck, ND 58505-0240. The telephone number is 701-328-2621.
- G. Illustrations
  - b. The following illustrations are examples of trucks that can be approved for a

bridge length permit.

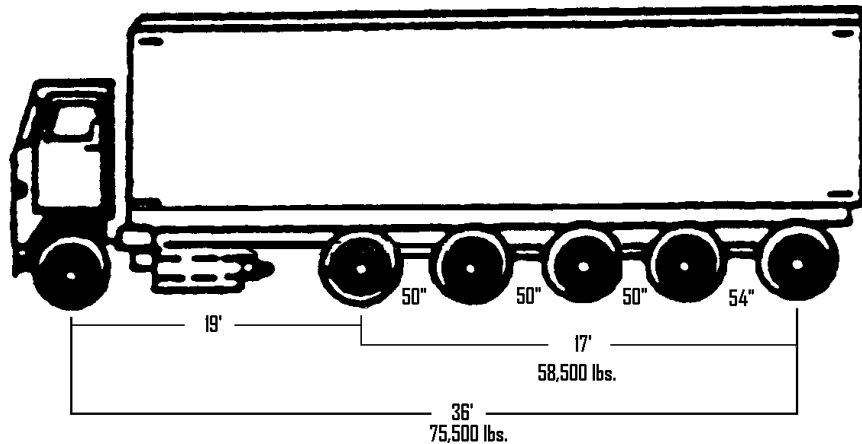

Gross Vehicle Weight of "Example" Vehicle above

75,500 pounds on state system with bridge length permit  
67,250 pounds on state system without approval

75,500 pounds on interstate system (I-29 & I-94) – no permit required

Steering Axle Weight

17.5" = 19,250 pounds

5 Axle Grouping Weights

58,500 pounds on state system with bridge length permit  
48,000 pounds without permit  
58,500 pounds on interstate system (I-29 & I-94) – no permit require

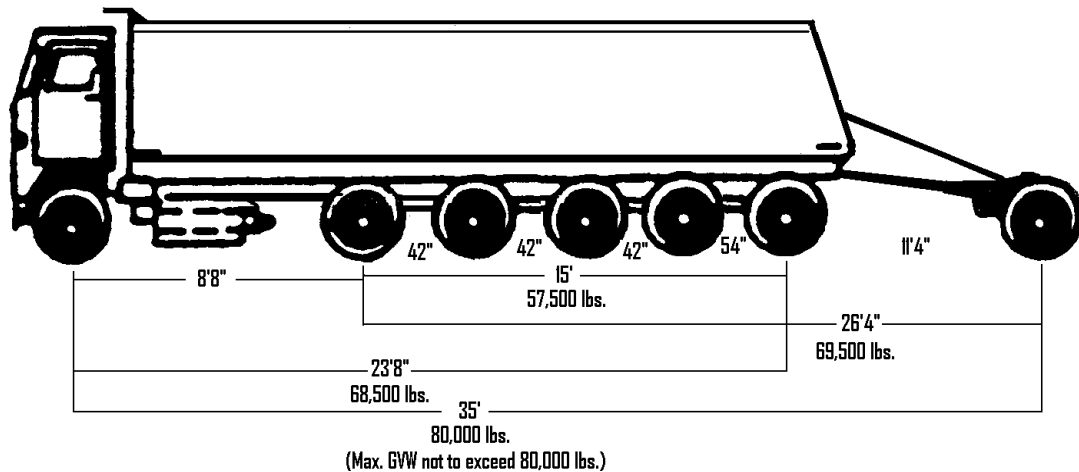

Gross Vehicle Weight of "Example" Vehicle above  
 80,000 pounds on state system with bridge length permit

78,470 pounds on state system without permit (5 axle group cannot exceed 48,000 pounds)

80,000 pounds on interstate system (I-29 & I-94) – no permit required

5 Axle Grouping Weights

57,500 pounds on state system with bridge length permit

48,000 pounds on state system without permit

57,500 pounds on interstate system (I-29 and I-94) – no permit required

Steering Axle Weight

425 m = 16.7" tire = 18,370 pounds

Single Axle Weight (stinger)

11" tire – 12,100 pounds

\*No tire shall exceed 550 pounds per inch width of tire.